

OLEODINAMICA • HYDRAULIC SECTION**Martinetti idraulici e meccanici**

**Cilindri idraulici
Pompe a leva
Tubi flessibili**

Pattini per trasporto carichi

**Sollevatori a magneti permanenti
con leva di comando**

Hydraulic and mechanical jacks

***Hydraulic cylinders
Hydraulic hand pumps
Flexible hoses***

Transport rollers

***Permanent magnet
lifters control lever***

INTERFRON 

INTERFRON Srl
Via Canale, 2 - 16035 Rapallo (GE) - Italy
Tel. +39 0185 263636 - Fax +39 0185 263355
[e mail vendite@interfron.it](mailto:mail_vendite@interfron.it)
www.interfron.it

MARTINETTI IDRAULICI SUN JACK**Applicazioni:**

Compatti, maneggevoli e di facile manutenzione, trovano largo impiego nelle industrie, miniere, settore automobilistico, ecc.

I martinetti Sun Jack possono lavorare solo in posizione verticale e non devono essere usati in orizzontale. Non possono lavorare in ambienti acidi o in presenza di gas corrosivi.

MARTINETTI IDRAULICI VICTORY**Applicazioni:**

Il martinetto per tutte le situazioni in tutte le posizioni

- rotazione dell'ungchia di sollevamento di 360°
- presa di carico a livello suolo
- utilizzabile in tutte le posizioni
- identica portata per unghia e testa
- grande stabilità
- prevenzione sovraccarico mediante limitatore di pressione
- bloccaggio istantaneo
- controllo della velocità di discesa
- raggio di manovra orientabile a 360°

BINDE "BULL" A CREMAGLIERA

Le binde a cremagliera "Bull" sono particolarmente robuste, di facile manutenzione e dotate di sicurezza a pressione di carico.

CILINDRI IDRAULICI LARZEP

Vasta gamma di sistemi idraulici a pressione.

Per ottenere la massima sicurezza ed efficienza nonché lunga durata del prodotto, leggere attentamente le istruzioni fornite con il materiale.

Per maggiori informazioni interpellateci.

MARTINETTI MECCANICI A BOTTIGLIA "MEC JACK"

Potenti, leggeri e di minimo ingombro, con testa, ingranaggi e base in acciaio legato trattato termicamente.

Meccanismo a cremagliera incorporato.

Idonei per ponti, strutture metalliche, presse, cantieri navali ed in tutte le industrie in cui si richiede un posizionamento multidirezionale anche in prossimità di fonti di calore.

MARTINETTI IDRAULICI "SOL JACK"

L'estrema leggerezza dei martinetti Sol Jack è stata ottenuta con un disegno pratico e compatto e l'impiego di alluminio ad alta resistenza.

La maniglia di trasporto è posta in maniera da permettere il trasporto con una sola mano.

Può essere utilizzato sia in posizione verticale che orizzontale, mentre una valvola di regolazione previene eventuali sovraccarichi.

Su richiesta il martinetto può essere fornito completo di manometro.

Il modello serie "HV" con pistone a vite ed anello di tenuta per bloccare il pistone meccanicamente, è ideale per tutte quelle operazioni di sollevamento dove si rende necessario sostenere il peso in sicurezza per lunghi periodi di tempo.

PATTINI "INTER-ROLL"**SOLLEVATORI A MAGNETI PERMANENTI INTERFIX**

Il sollevatore a magneti permanenti è dotato di un sistema di sospensione ad anello e quindi può funzionare solo se appeso ad un gancio del mezzo di sollevamento

Scelta del modello e caratteristiche tecniche

I parametri che devono essere attentamente considerati nella scelta sono:

La portata:

- dovrà essere determinata dal peso del carico massimo da sollevare. Non dovrà mai risultare superiore a quella dell'attrezzatura di sollevamento (paranco, gru, ecc.)

La natura del carico:

- Il materiale deve essere ferromagnetico, avere una superficie piana e pulita, con spessore adeguato. L'acciaio da movimentare deve essere a basso tenore di carbonio, altrimenti - qualora fosse "legato" - bisogna tenere conto di opportune riduzioni.

Cosa non fare mai

- non sollevare dei carichi mentre le persone transitano nell'area di manovra sottostante
- non consentire l'uso del sollevatore a personale non qualificato o minore di anni 16
- non lasciare il carico sospeso incustodito
- non sollevare carichi non equilibrati
- non sollevare più di un pezzo alla volta
- non far oscillare il carico durante la traslazione
- non urtare con il carico le strutture del capannone o altre macchine ed impianti

SUN JACK HYDRAULIC JACKS**Applications:**

The hydraulic jack is a simple lifting device, compact in construction, portable, and easy to maintain. It is suitable for use in factories, mines and for garage work. The jack can operate in a vertical position and cannot be used in a horizontal or up-side-down position. It should not be used in places where acid, alkalis or corrosive gas exists.

VICTORY HYDRAULIC JACKS**Applications:**

The jack for every situation in every position

- full rotation of the toe to 360°
- picks up loads at ground level
- usable in any position
- identical capacity both at toe and head
- high stability
- overloading prevented by pressure limiter
- instantaneous stop mechanism
- lowering speed control
- adjustable operating lever with 360° turning

"BULL" MECHANICAL RACK JACKS

These jacks are used for heavy lifting, easy to handle, assuring total safety features.

LARZEP HYDRAULIC CYLINDERS

Very large range of high pressure hydraulic equipment. To obtain the maximum of safety, efficiency and long life, please read carefully the instruction booklet which is supplied with the equipment.

For more information you can apply to our Service Department.

"MEC JACK" MECHANICAL JACKS

Powerful, light, low height, cap, gears and base are heat-treated, alloy steel forgings.

Ratchet mechanisms, fully enclosed

For bridge, structural steel erector, presses, ship-building and all industries where all position jacks are required, also near heated environment.

"SOL JACK" HYDRAULIC JACKS

Designed with a cast aluminium cover incorporating a lifting handle and a solid extruded aluminum base.

Can be used in an upright position or horizontal on the flat front face, relief valve prevents overloading.

Pressure gauge can be fitted as an optional extra.

The "HV" series screwed ram and locking collar make this an ideal jack for all lifting operations where it is necessary to sustain the load in safety over long periods of time.

"INTER-ROLL" TRANSPORT ROLLERS**INTERFIX PERMANENT MAGNET LIFTERS**

The permanent magnetic hoisting device is equipped with a ring suspension system and therefore works only if suspended from the hook of hoisting equipment.

Model choice and specifications

The parameters that must be carefully considered in making the choice are:

Carrying capacity:

- maximum weight of the load to be hoisted must be determined. It must never be more than that of the hoisting equipment (hoist, crane, etc.).

The nature of the load:

- The material must be ferromagnetic, have a smooth, clean surface with an adequate thickness. The steel to be moved must be at a low carbon content otherwise - in case it's an "alloy" - special reductions must be taken into account.

Never do the following:

- do not lift loads while people are passing below the maneuvering area
- do not allow use of the hoisting device to unqualified personnel or minors 16 years or younger
- do not leave the suspended load unattended
- do not lift unbalanced loads
- do not lift more than one part at time
- do not cause the load to oscillate during transfer
- do not bump the load into the building structure or other machines or systems

MARTINETTI IDRAULICI SUN JACK

"SUN JACK"
HYDRAULIC BOTTLE JACKS

CODICE CODE NO.	WLL KG	CORSA LIFT MM	ALTEZZA MIN. MINIMUM HEIGHT MM	ALZATA REGOLABILE ADJUSTING HEIGHT MM	PESO WEIGHT KG	PREZZO PRICE €
FBJ002	2.000	116	181	48	2,9	
FBJ003	3.000	118	194	60	3,6	
FBJ005	5.000	127	216	70	4,8	
FBJ012	12.000	155	230	60	8,0	
FBJ015	15.000	150	230	60	8,9	
FBJ050	50.000	180	305		42,0	



MARTINETTI IDRAULICI VICTORY

"VICTORY"
HYDRAULIC JACKS

CODICE CODE NO.	WLL KG	CORSO LIFT MM	ALTEZZA DI PRESA MIN. PICKING UP POSITION HEIGHT MM		SFORZO SULLA LEVA A PIENO CARICO STRESS ON LEVER AT MAXIMUM LOAD KG	LUNGH. UNGHIA LENGTH OF THE TOE MM	PESO WEIGHT KG.	PREZZO PRICE €
			CON UNGHIA AT BASE	CON TESTA AT TOP				
FVYU05	5.000	206	25	368	38	55	20,0	
FVYU10	10.000	233	25	413	40	55	27,5	
FVYU25	25.000	233	54	470	40	90	92,0	

CILINDRI IDRAULICI LARZEP
LARZEP HYDRAULIC CYLINDERS
SM SEMPLICE EFFETTO RITORNO A MOLLA
SIMPLE ACTING CYLINDERS SPRING RETURN

CODICE CODE NO.	WLL Kn (TON)	CORSA LIFT MM	ALTEZZA CHIUSO COLLAPSED HEIGHT MM
SM00502	48,5 (5)	25	110
SM00508	48,5 (5)	76	168
SM00513	48,5 (5)	127	219
SM00518	48,5 (5)	180	276
SM00523	48,5 (5)	232	328
SM01002	109,2 (10)	25	90
SM01005	109,2 (10)	54	121
SM01010	109,2 (10)	105	172
SM01015	109,2 (10)	155	247
SM01020	109,2 (10)	205	301
SM01025	109,2 (10)	257	352
SM01030	109,2 (10)	307	402
SM01035	109,2 (10)	355	454
SM01502	163 (15)	25	127
SM01505	163 (15)	54	155
SM01510	163 (15)	105	205
SM01515	163 (15)	155	275
SM01520	163 (15)	205	327
SM01525	163 (15)	257	379
SM01530	163 (15)	307	426
SM01535	163 (15)	355	477
SM02302	227,8 (23)	25	140
SM02305	227,8 (23)	51	166
SM02310	227,8 (23)	102	217
SM02315	227,8 (23)	159	277
SM02321	227,8 (23)	210	327
SM02326	227,8 (23)	261	379
SM02331	227,8 (23)	310	430
SM02336	227,8 (23)	362	480
SM03006	303,2 (30)	60	165
SM03015	303,2 (30)	150	270
SM03021	303,2 (30)	210	340
SM05006	486,5 (50)	60	176
SM05010	486,5 (50)	102	227
SM05016	486,5 (50)	160	285
SM05034	486,5 (50)	339	465
SM07516	712,9 (75)	160	285
SM07533	712,9 (75)	330	495
SM10006	911 (100)	60	180
SM10015	911 (100)	150	300
SM10026	1380 (140)	260	449
SM14006	1380 (140)	60	190
SM14015	1380 (140)	150	320
SM14026	1380 (140)	260	470
SM22015	2156 (220)	150	340

SEMPLICE EFFETTO RITORNO A MOLLA **SINGLE ACTING CYLINDERS**
SMX EXTRA PIATTI **SMX EXTRA PIATTI**
SMP COMPATTI **SMP COMPATTI**

CODICE CODE NO.	WLL Kn (TON)	CORSA LIFT MM	ALTEZZA CHIUSO COLLAPSED HEIGHT MM
SMX00406	43,8 (4)	6	32,5
SMX00416	43,8 (4)	16	42,5
SMX01011	99,7 (10)	11	43
SMX02211	227,8 (22)	11	52
SMX03013	287,3 (30)	13	59
SMX05016	486,5 (50)	16	68
SMX07516	712,9 (75)	16	79
SMX10016	953,6 (100)	16	87
SMX15016	1450 (150)	16	100
SMP01004	109 (10)	40	89
SMP02004	214 (20)	40	101
SMP03006	303 (30)	60	125
SMP05006	486 (50)	60	125
SMP10006	911 (100)	60	141
SMP10015	911 (100)	150	254

STX SEMPLICE EFFETTO CON GHIERA DI SICUREZZA RIBASSATI
PANCAKE LOCK NUT CYLINDERS

CODICE CODE NO.	WLL Kn (TON)	CORSA LIFT MM	ALTEZZA CHIUSO COLLAPSED HEIGHT MM
STX05005	486 (50)	50	125
STX09004	911 (90)	45	137
STX14004	1380 (140)	45	148
STX22004	2156 (220)	45	155
STX35004	3468 (350)	45	178
STX56004	5520 (550)	45	192

TE - TD - T SEMPLICE EFFETTO TRAENTI
PULL CYLINDERS

CODICE CODE NO.	WLL Kn (TON)	CORSA LIFT MM	LUNGHEZZA LENGTH MM
TE01015	93,2 (10)	150	576
TE03015	301,8 (30)	150	723
TE05015	483,2 (50)	150	757
TD01015	93,2 (10)	150	576
TD03015	301,8 (30)	150	723
TD05015	483,2 (50)	150	757
T00514/5	53,9 (5)	140	306
T00514/10	53,9 (5)	140	306
T01015	93,2 (10)	140	308

CILINDRI IDRAULICI LARZEP
LARZEP HYDRAULIC CYLINDERS
**D CILINDRI DOPPIO EFFETTO
DOUBLE EFFECT**

CODICE CODE NO.	SPINTA PUSH Kn (TON)	TRAZIONE PULL Kn	CORSA LIFT MM	ALTEZZA CHIUSO COLLAPSED HEIGHT MM
D01016	109 (10)	20	160	310
D01025	109 (10)	20	250	400
D01032	109 (10)	20	320	470
D02016	214 (20)	53	160	320
D02025	214 (20)	53	250	410
D02032	214 (20)	53	320	480
D03016	303 (30)	68	160	335
D03032	303 (30)	68	320	495
D05016	486 (50)	72	160	335
D05032	486 (50)	72	320	510
D07516	712 (75)	140	160	338
D07532	712 (75)	140	320	512
D10016	912 (100)	189	160	339
D10032	911 (100)	189	320	509
D15005	1380 (150)	370	50	258
D15015	1380 (150)	370	150	378
D15030	1380 (150)	370	300	528
D20005	2156 (200)	560	50	274
D20015	2156 (200)	560	150	394
D20030	2156 (200)	560	300	544
D35005	3368 (350)	1014	50	299
D35015	3368 (350)	1014	150	419
D35030	3368 (350)	1014	300	569

**SEMPLICE EFFETTO RITORNO A MOLLA
SAM IN ALLUMINIO
SAH IN ALLUMINIO FORATI**
**SINGLE ACTING CYLINDERS
SAM ALUMINIUM
SAH ALUMINIUM HOLLOW PLUNGER**

CODICE CODE NO.	WLL Kn (TON)	CORSA LIFT MM	Ø FORO Ø HOLE MM	ALTEZZA CHIUSO COLLAPSED HEIGHT MM
SAM02305	227,8 (23)	50		164
SAM02310	227,8 (23)	100		214
SAM02315	227,8 (23)	150		264
SAM03005	303,2 (30)	50		174
SAM03010	303,2 (30)	100		224
SAM03015	303,2 (30)	150		274
SAM05005	486,5 (50)	50		193
SAM05010	486,5 (50)	100		243
SAM05015	486,5 (50)	150		293
SAM10005	911 (100)	50		230
SAM10010	911 (100)	100		280
SAM10015	911 (100)	150		330
SAH03010	301,8 (30)	100	33,4	272
SAH06010	578,2 (60)	100	54	288
SAH10010	1018 (100)	100	80	326

**CILINDRI FORATI
SH SEMPLICE EFFETTO
DH DOPPIO EFFETTO**
**HOLLOW PLUNGER CYLINDERS
SH SIMPLE EFFECT
H DOUBLE EFFECT**

CODICE CODE NO.	SPINTA PUSH Kn (TON)	TRAZIONE PULL Kn	CORSA LIFT MM	Ø FORO Ø HOLE MM	ALTEZZA CHIUSO COLLAPSED HEIGHT MM
SH01204	121 (12)		40	19,5	124
SH01208	121 (12)		76	19,5	176
SH01215	121 (12)		150	19,5	300
SH02205	217 (22)		50	27	165
SH02215	217 (22)		150	27	318
SH03005	301,8 (30)		50	33,4	180
SH03015	301,8 (30)		150	33,4	322
SH06008	578,2 (60)		76	54	253
SH06015	578,2 (60)		153	54	341
SH10008	1018 (100)		80	80	306
DH03015	301,8 (30)	172,5	150	33,4	300
DH03025	301,8 (30)	172,5	250	33,4	400
DH06008	578,1 (60)	355,7	80	54	249
DH06015	578,1 (60)	355,7	150	54	319
DH06025	578,1 (60)	355,7	250	54	419
DH10004	1018 (100)	646,8	38	80	197
DH10008	1018 (100)	646,8	76	80	255
DH10015	1018 (100)	646,8	150	80	335
DH10025	1018 (100)	646,8	250	80	465
DH15018	1407 (150)	566	175	80	350

**SL TELESCOPICI
TELESCOPIC CYLINDERS**

CODICE CODE NO.	WLL Kn (TON)	CORSA LIFT MM	ALTEZZA CHIUSO COLLAPSED HEIGHT MM
SL01027	109,1 (10)	270	250
SL01043	109,1 (10)	435	280
SL01530	162,7 (15)	300	280
SL01550	162,7 (15)	500	320
SL03030	303,2 (30)	300	304
SL03060	303,2 (30)	600	366



CILINDRI IDRAULICI LARZEP
LARZEP HYDRAULIC CYLINDERS
SSR
SEMPLICE EFFETTO ALTO TONNELLAGGIO
SIMPLE EFFECT, HIGH TONNAGE

DDR
DOBPIO EFFETTO ALTO TONNELLAGGIO
DOUBLE EFFECT, HIGH TONNAGE

ST
SEMPLICE EFFETTO CON GHIERA DI SICUREZZA
SIMPLE EFFECT, LOCK NUT CYLINDERS

CODICE CODE NO.	WLL Kn (TON)	CORSA STROKE MM	ALTEZZA CHIUSO COLLAPSED HEIGHT MM	CODICE CODE NO.	WLL Kn (TON)	TRAZIONE PULL Kn	CORSA STROKE MM	ALTEZZA CHIUSO COLLAPSED HEIGHT MM	CODICE CODE NO.	WLL Kn (TON)	CORSA STROKE MM	ALTEZZA CHIUSO COLLAPSED HEIGHT MM
									ST03005	303 (30)	50	169
									ST03010	303 (30)	100	219
									ST03015	303 (30)	150	269
									ST03020	303 (30)	200	319
									ST03030	303 (30)	300	419
									ST05005	486 (50)	50	185
SSR14005	1380 (140)	50	155	DDR14005	1380 (140)	728	50	201	ST05010	486 (50)	100	235
SSR14010	1380 (140)	100	205	DDR14010	1380 (140)	728	100	251	ST05015	486 (50)	150	285
SSR14015	1380 (140)	150	255	DDR14015	1380 (140)	728	150	306	ST05020	486 (50)	200	335
SSR14020	1380 (140)	200	305	DDR14020	1380 (140)	728	200	356	ST05030	486 (50)	300	435
SSR14025	1380 (140)	250	355	DDR14025	1380 (140)	728	250	411	ST10005	911 (100)	50	200
SSR14030	1380 (140)	300	405	DDR14030	1380 (140)	728	300	461	ST10010	911 (100)	100	250
SSR22005	2156,2 (220)	50	170	DDR22005	2157 (220)	1100	50	216	ST10015	911 (100)	150	300
SSR22010	2156,2 (220)	100	220	DDR22010	2157 (220)	1100	100	266	ST10020	911 (100)	200	350
SSR22015	2156,2 (220)	150	270	DDR22015	2157 (220)	1100	150	326	ST10030	911 (100)	300	450
SSR22020	2156,2 (220)	200	320	DDR22020	2157 (220)	1100	200	376	ST14005	1380 (140)	50	211
SSR22025	2156,2 (220)	250	370	DDR22025	2157 (220)	1100	250	436	ST14010	1380 (140)	100	259
SSR22030	2156,2 (220)	300	420	DDR22030	2157 (220)	1100	300	486	ST14015	1380 (140)	150	309
SSR35005	3369,1 (350)	50	210	DDR35005	3369 (350)	1213	50	231	ST14020	1380 (140)	200	359
SSR35010	3369,1 (350)	100	260	DDR35010	3369 (350)	1213	100	281	ST14030	1380 (140)	300	459
SSR35015	3369,1 (350)	150	310	DDR35015	3369 (350)	1213	150	341	ST20005	2156 (200)	50	245
SSR35020	3369,1 (350)	200	360	DDR35020	3369 (350)	1213	200	391	ST20010	2156 (200)	100	345
SSR35025	3369,1 (350)	250	410	DDR35025	3369 (350)	1213	250	451	ST20015	2156 (200)	150	345
SSR35030	3369,1 (350)	300	460	DDR35030	3369 (350)	1213	300	501	ST20025	2156 (200)	250	445
SSR56005	5520 (560)	50	240	DDR56005	5520 (560)	2150	50	268	ST35005	3369 (350)	50	275
SSR56010	5520 (560)	100	290	DDR56010	5520 (560)	2150	100	318	ST35010	3369 (350)	100	345
SSR56015	5520 (560)	150	340	DDR56015	5520 (560)	2150	150	373	ST35015	3369 (350)	150	395
SSR56020	5520 (560)	200	390	DDR56020	5520 (560)	2150	200	423	ST35025	3369 (350)	250	495
SSR56025	5520 (560)	250	440	DDR56025	5520 (560)	2150	250	488	ST43005	4226 (430)	50	335
SSR56030	5520 (560)	300	490	DDR56030	5520 (560)	2150	300	538	ST43010	4226 (430)	100	385
SSR88005	8625 (880)	50	290	DDR88005	8624 (880)	3103	50	310	ST43015	4226 (430)	150	435
SSR88010	8625 (880)	100	340	DDR88010	8624 (880)	3103	100	360	ST43025	4226 (430)	250	535
SSR88015	8625 (880)	150	390	DDR88015	8624 (880)	3103	150	420	ST56005	5520 (560)	50	345
SSR88020	8625 (880)	200	440	DDR88020	8624 (880)	3103	200	470	ST56010	5520 (560)	100	425
SSR88025	8625 (880)	250	490	DDR88025	8624 (880)	3103	250	530	ST56015	5520 (560)	150	475
SSR88030	8625 (880)	300	540	DDR88030	8624 (880)	3103	300	580	ST56025	5520 (560)	250	575
SSR110005	10916 (1100)	50	415	DDR110005	10915 (1100)	3932	50	330	ST67005	6604 (670)	50	395
SSR110010	10916 (1100)	100	465	DDR110010	10915 (1100)	3932	100	380	ST67010	6604 (670)	100	445
SSR110015	10916 (1100)	150	515	DDR110015	10915 (1100)	3932	150	440	ST67015	6604 (670)	150	495
SSR110020	10916 (1100)	200	565	DDR110020	10915 (1100)	3932	200	490	ST67025	6604 (670)	250	595
SSR110025	10916 (1100)	250	615	DDR110025	10915 (1100)	3932	250	550	ST88005	8625 (880)	50	400
SSR110030	10916 (1100)	300	665	DDR110030	10915 (1100)	3932	300	600	ST88010	8625 (880)	100	505
									ST88015	8625 (880)	150	555
									ST88025	8625 (880)	250	655
									ST110005	10916 (1100)	50	443
									ST110010	10916 (1100)	100	548
									ST110015	10916 (1100)	150	598
									ST110025	10916 (1100)	250	698

CILINDRI IDRAULICI LARZEP
LARZEP HYDRAULIC CYLINDERS

**W POMPE OLEODINAMICHE MANUALI A SEMPLICE EFFETTO
HYDRAULIC HAND PUMPS**
**X POMPE OLEODINAMICHE MANUALI A DOPPIO EFFETTO
HYDRAULIC HAND PUMPS DOUBLE ACTING**

CODICE CODE NO.	1° STADIO 1° STEP cm ³	2° STADIO 2° STEP cm ³	CAPACITA' UTILE CAPACITY cm ³	PESO WEIGHT KG
W00307	-	1,6	240	2,7
W10707	-	2,6	660	5,5
W20707	8,1	2	660	5,5
W11207	-	2,6	1200	6,5
W21207	8,1	2	1200	6,5
W22307	13,2	2,2	2400	12
W24307	16,5	2,8	4200	20
W07807	70,5	2,6	7500	30
X22307	13,2	2,2	2400	14
X24307	16,5	2,8	4200	23
X07807	70,5	2,6	7500	30

CENTRALINE CON MOTORE ELETTRICO
YAE CON ELETTROVALVOLA
YAM CON VALVOLA MANUALE

**HYDRAULIC ELECTRIC PUMPS
YAE ELECTRIC VALVE
YAM MANUAL VALVE**



CODICE CODE NO.	CONTROLLO CHECK M/E	S/D	1° STADIO 1° STEP L/min	2° STADIO 2° STEP L/min	SERB. OLIO L
YAM4xxx	M	S/D	-	1,4	20 - 50
YAE4xxx	E	S/D	-	1,4	20 - 50
YAM5xxx	M	S/D	-	1,3	10 - 40
YAE5xxx	E	S/D	-	1,3	10 - 40
YAM6xxx	M	S/D	3	0,56	4 - 40
YAE6xxx	E	S/D	3	0,56	4 - 40
YAM7xxx	M	S/D	-	2,1	15 - 40
YAE7xxx	E	S/D	-	2,1	15 - 40

**YGM CENTRALINE CON MOTORE A SCOPIO
PETROL HYDRAULIC PUMPS**

CODICE CODE NO.	CONTROLLO CHECK M/E	S/D	0 bar L/min	700 bar L/min	SERB. OLIO L
YGM242	M	S	0,65	0,56	10
YGM244	M	D	0,65	0,56	10
YGM252	M	S	0,65	0,56	15
YGM254	M	D	0,65	0,56	15
YGM262	M	S	0,65	0,56	40
YGM264	M	D	0,65	0,56	40

**Z POMPA PNEUMOIDRAULICA
AIR HYDRAULIC PUMP**

Semplice effetto - Simple effect
0,13 L/min. (700 bar)
2,1 L cap. - 6,4 Kg.

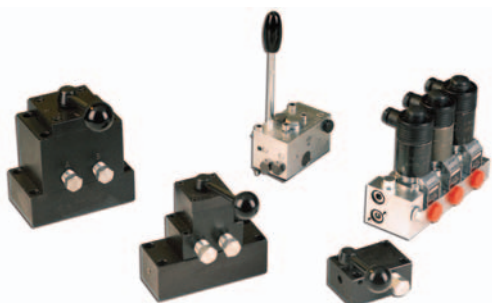
ACCESSORI
ACCESSORIES

CILINDRI IDRAULICI LARZEP
LARZEP HYDRAULIC CYLINDERS
EC-EG-EM-EE-EZ
PRESSE OLEODINMICHE
HYDRAULIC PRESSES

CODICE CODE NO.	TIPO PRESSA PRESS TYPE	WLL TON	CORSA STROKE MM	A X B MAX MM
ECM01113	B - M	10	130	350 x 352
ECZ01113	B - Z	10	130	350 x 352
ECE01113	B - E	10	130	350 x 352
ECE01113CE	B - E - CE	10	130	350 x 352
ECM02013	B - M	20	130	500 x 330
ECZ02013	B - Z	20	130	500 x 330
ECE02013	B - E	20	130	500 x 330
ECE02013CE	B - E - CE	20	130	500 x 330
EM03012	C - M	30	95	500 x 930
EZ03012	C - Z	30	95	500 x 930
EE03116	C - E	30	160	500 x 930
EE03116CE	C - E - CE	30	160	500 x 930
EZ06018	C - G	60	180	860 x 935
EM06018	C - M	60	180	860 x 935
EE06018	C - Z	60	180	860 x 935
EE06018CE	C - E - CE	60	180	860 x 935
EZ12018	C - M	60	180	880 x 910
EE12018	C - E	120	180	880 x 910
EE12018CE	C - E - CE	120	180	880 x 910
EE25030CE	C - E - CE	250	300	1080 x 1000

“Z”: Con pompa pneumoidraulica
 “B”: Da banco
 “C”: A colonna
 “E”: Con centralina elettrica
 “G”: Con cricco manuale
 “M”: Con pompa manuale
 “CE”: Con pulsantiera elettrica

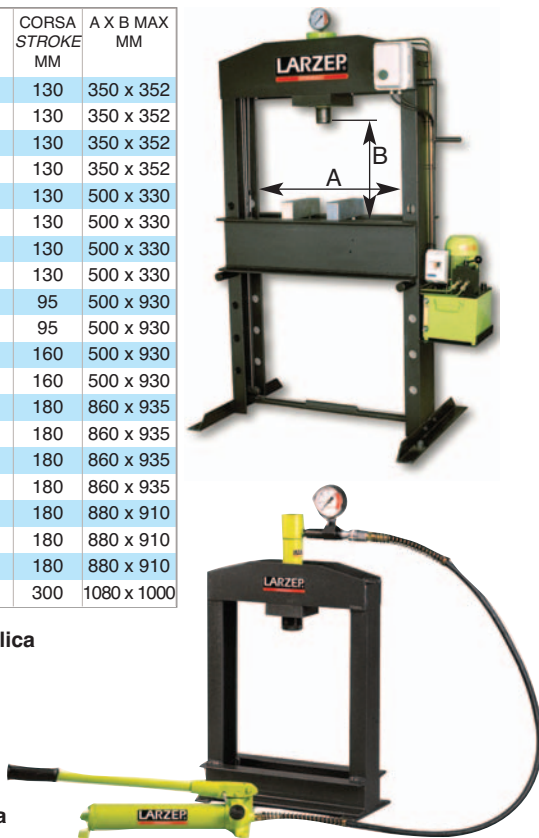
F TAVOLE OLEODINMICHE
HYDRAULIC TABLES



CODICE CODE NO.	WLL TON	A mm	B mm	C mm
F005121	500	520	1080	270
F01571	1500	520	1080	235

VA-VB-VC-VZ SET PIEGATUBI
HYDRAULIC BENDERS

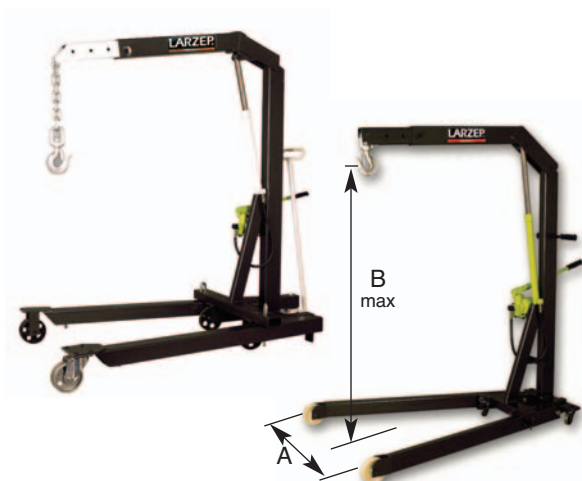
3/8" - 1/2" - 3/4" - 1" - 1 1/4" - 1 1/2"
 2" - 2 1/2" - 3"

DLG-DL-DP GRU OLEODINMICHE PORTATILI E RIPIEGHEVOLI
PORTABLE HYDRAULIC CRANES

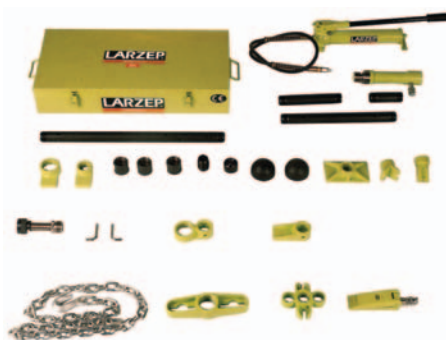
CODICE CODE NO.	WLL TON	A MIN. MM	B MAX MM
DLG005	0,5	860	2190
DLG010	1	1000	2420
DLG020	2	1220	2770

CA SET DI MANUTENZIONE
MAINTENANCE UNIT

CODICE CODE NO.	WLL TON
CA0513	5
CA1113	10
CA2013	20

CILINDRI IDRAULICI LARZEP

LARZEP HYDRAULIC CYLINDERS

FU ESTRATTORI OLEODINAMICI
HYDRAULIC PULLERS

CODICE CODE NO.	WLL TON
FU0500	0,5
FU1000	1
FU2000	20
FU3000	30
FU5000	50

CY PINZE DIVARICATRICI
SPREAD CYLINDERS

CODICE CODE NO.	WLL Kn (TON)	A MM	B MM
CY0109	9,81 (1)	15	90
CY00822	7,8 (0,8)	31	220

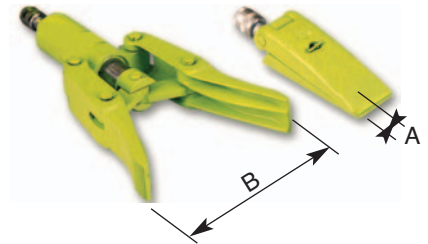
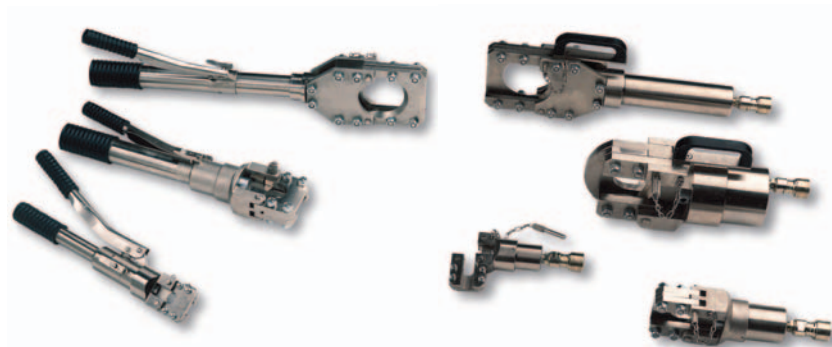
CC TAGLIACAVI
HYDRAULIC CABLE CUTTERS

CODICE CODE NO.	WLL TON	Ø FUNE ESTERNO Ø ROPE MM	PESO WEIGHT KG
CC.01.18	5	18	2
CC.01.40	14	40	4,5
CC.01.75	7	★	5,5
CC.01.90	11	★	9,4
CC.01.120	14	★	11,7
CC.01.60	45	60	12
CC.02.60	40	60	12

★ Non adatto a taglio di funi

CN SPACCA DADI
NUT SPLITTERS

CODICE CODE NO.	WLL TON	MASSIMA RESISTENZA 8.8 MM	PESO WEIGHT KG
CN0024	13,8	M12 - M24 (1/2" - 7/8")	4,30
CN0224	13,5	M12 - M24 (1/2" - 7/8")	3,70
CN0233	35	M25 - M33 (1" - 2")	15
CN0152	43,9	M36 - M52 (1 1/2" - 2)	13
CN0180	113,4	M72 - M80 (2 3/4" - 3")	40
CN0324	13,5	M16 - M24 (5/8" - 7/8")	5

CT-C DINAMOMETRI DA 5÷10
DYNAMOMETERSCK TAGLIA CATENE
HYDRAULIC CHAIN CUTTERS

CODICE CODE NO.	WLL TON	Ø CATENA Ø CHAIN MAX MM	PESO WEIGHT KG
CK0016	14	19	5,1
CK0116	14	19	4,5
CK0130	39	30	14,0
CK0230 ★	35	30	16,0
CK0250 ★	112	50	80,0

★ I modelli CK0230 e CK0250 sono a doppio effetto



MARTINETTI IDRAULICI SOL JACK

"SOL JACK" HYDRAULIC JACKS

SERIE "M"
"M" SERIESSERIE "HS" Pistone liscio
"HS" SERIES Plain ram

CODICE CODE NO.	WLL TON	CORSA LIFT MM	A MM	B MM	LARGH. MAX MAX WIDTH MM	SERIE SERIES	PESO WEIGHT KG	PREZZO PRICE €
F006LA	6,5	75	131	159	76	M	3,6	PREZZI A RICHIESTA PRICES UPON REQUEST
F010LA	10,0	115	182	171	76	M	6,3	
F015LA	15,0	152	230	197	92	M	10,0	
F020LA	20,0	152	257	191	130	HS	13,6	
F020LB	20,0	305	445	267	130	HS	20,4	
F030LA	30,0	152	281	197	140	HS	20,4	
F060LA	60,0	152	292	260	197	HS	31,3	
F060LB	60,0	305	506	348	197	HS	50,8	
F100LA	100,0	152	310	305	240	HS	49,0	

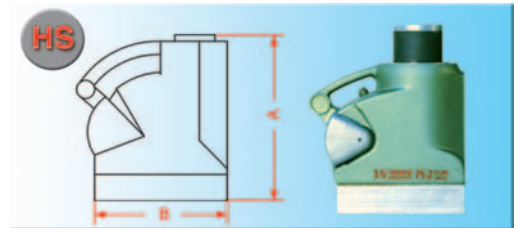
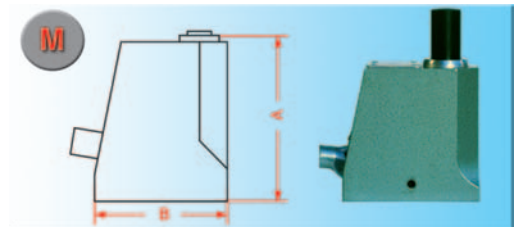
SERIE "HV" - Pistone a vite
"HV" SERIES - Screwed ram

CODICE CODE NO.	WLL TON	CORSA LIFT MM	A MM	B MM	LARGH. MAX MAX WIDTH MM	PESO WEIGHT KG	PREZZO PRICE €
F020VA	20,0	152	283	191	130	14,1	PREZZI A RICHIESTA PRICES UPON REQUEST
F020VB	20,0	305	470	267	130	20,9	
F030VA	30,0	305	470	273	140	23,4	
F060VA	60,0	152	330	260	197	33,2	
F060VB	60,0	305	544	348	197	52,0	
F100VA	100,0	152	360	305	240	53,0	

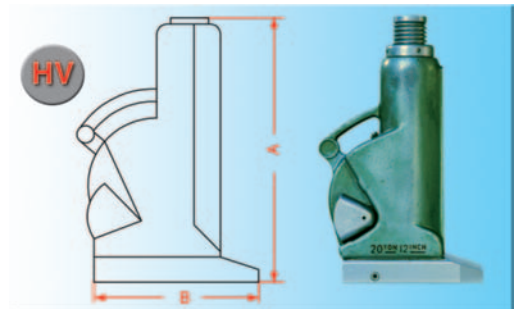
SERIE "HC" - Con unghia
"HC" SERIES - Claw type

CODICE CODE NO.	WLL TON		CORSA LIFT MM	A MM	B MM	C MM	LARGH. MAX MAX WIDTH MM	PESO WEIGHT KG	PREZZO PRICE €
	TESTA/HEAD	UNGHIA/TOE							
F020UA	20,0	8	152	276	267	70	130	19,5	PREZZI A RICHIESTA PRICES UPON REQUEST
F020UB	20,0	8	305	464	267	70	130	28,2	
F060UA	60,0	24	152	325	348	72	197	49,0	
F060UB	60,0	24	305	469	348	72	197	76,6	

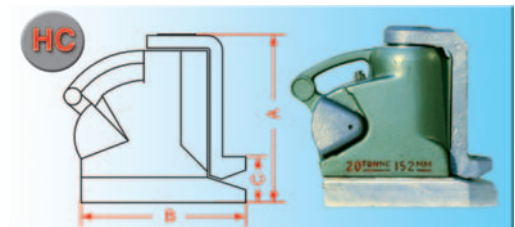

MARTINETTI MECCANICI A BOTTIGLIA MEC JACK

"MEC JACK"
MECHANICAL JACKS

CODICE CODE NO.	MODELLO MODEL	WLL TON	CORSA LIFT MM	ALTEZZA MIN MIN HEIGHT MM	DIAM. TESTA CAP DIAM MM	A MM	B MM	D MM	PESO WEIGHT KG	PREZZO PRICE €
F015KJ	15125	15	125	255	68	84	127	148	12	PREZZI A RICHIESTA PRICES UPON REQUEST
F025KJ	25125	25	125	255	78	99	139	166	16	
F035KJ	35130	35	130	280	94	99	161	180	24	
F050KJ	50130	50	130	290	106	109	183	215	32	
F010KA	10150	10	150	280	58	80	120	148	13	
F025KA	25250	25	250	400	78	99	139	166	24	
F035KA	35250	35	250	400	94	106	161	209	32	
F050KA	50250	50	250	445	106	109	183	215	44	
F100KA	100250	100	250	560	148	275	313	383	175	
F015KB	15250	15	250	380	68	84	127	148	17	
F025KB	25330	25	330	485	78	99	139	166	25	
F035KB	35400	35	400	625	94	106	161	209	43	
F050KB	50400	50	400	675	106	109	183	215	63	

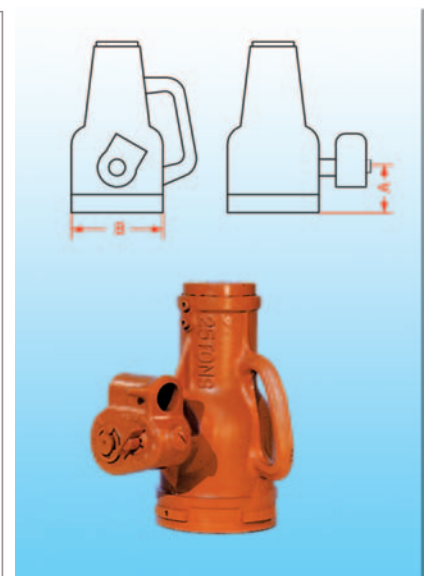

PATTINI "INTER-ROLL"
**"INTER-ROLL"
TRANSPORT ROLLERS**

Set idoneo per trasporto carichi • provvisto di ralla rotante e di rulli in acciaio rivestiti in poliuretano • lunghezza "D" registrabile • raccomandato per pavimenti piani e puliti

"INTER-ROLL" transport rollers set complete with rolling fifth wheel and steel rolls lined with polyurethane • length "D" adjustable • recommended for flat and clean floors.

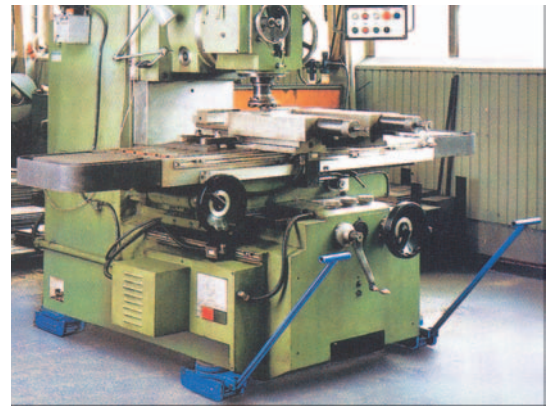
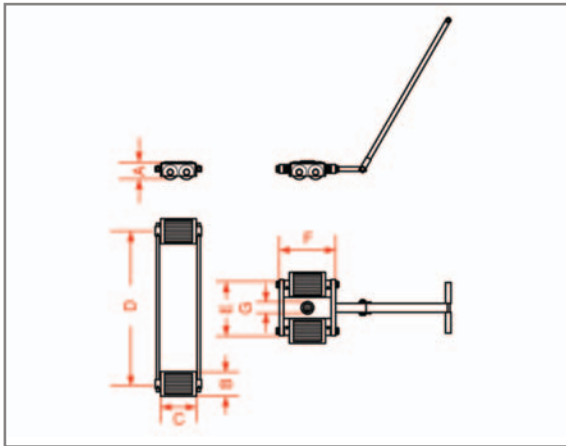

CODICE CODE NO.	WLL SET KG	ELEMENTI ROLLERS ROLLERS COMPONENTS NR.	A MM	B MM	C MM	D MM	E MM	F MM	G MM	PESO WEIGHT KG	PREZZO PRICE €
80PATT	8.000	4	100	200	140	960	325	320	100	60	

**INTERFIX - SOLLEVATORI A
MAGNETI PERMANENTI IN NEODIMIO**
EN 13155
**INTERFIX PERMANENT LIFTERS
WITH NEODYMIUM MAGNETS**

Questo articolo è costituito da un corpo in acciaio di grande robustezza e un circuito magnetico interno formato da magneti permanenti in lega NEODIMIO. La sua dimensione molto ridotta, unita alla forza molto elevata, lo rendono il miglior sollevatore attualmente presente sul mercato. La base del sollevatore ha una forma prismatica che lo rende ideale per sollevamenti di piatti e tondi al tempo stesso.

La possibilità di azionare il magnetismo con una sola mano rendono più pratico il sollevatore rispetto ad altri presenti sul mercato.

Risolve i problemi di sollevamento nei bassi spessori arrivando a sollevare anche lamiere con spessore minimo di 10 mm.

Garantito 12 mesi; la garanzia decade se il prodotto viene manomesso.

This item is made up by a steel with big strength and an internal magnetic circuit constituted by NEODYMIUM permanent magnets. Its very small size joined with the very high strength make it the best lifter on the market at present.

The prismatic shape of the lifter base make it ideal for lifting round and flat pieces in the same time.

The opportunity to operate the magnetism with only one hand, let this lifter more handy than others present on the market. It resolve first of all the problems connected with the lifting of thin thickness, even with a minimum of 10 mm. thickness sheet.

Guaranteed 12 months; the same will be declined tampering the lifter.

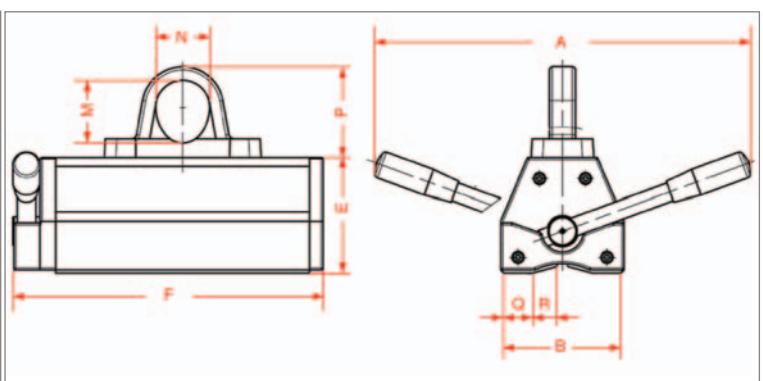
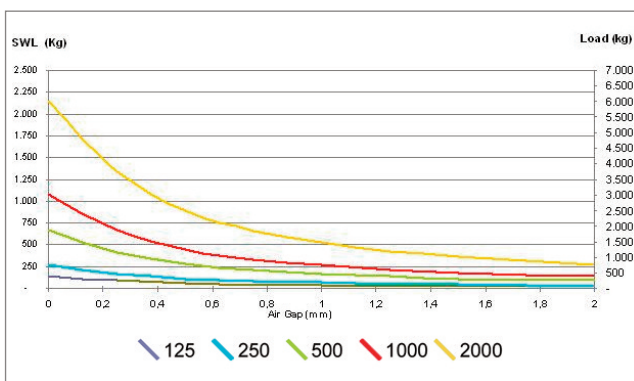

CODICE CODE NO.	WLL		min/mm	max mm	max/mm	A MM	B MM	E MM	F MM	M MM	N MM	P MM	Q MM	R MM	PESO WEIGHT KG	PREZZO PRICE
	KG	KG														
SPM012	125	60	10	180	2.000	220	78	81	160	43	35	63	16	18	6	
SPM025	250	125	15	270	2.000	374	118	115	196	43	35	63	24	30	14	
SPM050	500	250	20	220	2.500	380	118	115	296	60	52	92	31	23	26	
SPM100	1.000	500	30	360	3.000	420	148	145	355	60	52	92	42	27	45	
SPM200	2.000	1.000	30	340	3.000	550	177	190	544	87	64	130	59	25	95	

